

Warren®

VALVES

STAINLESS STEEL CAST BALL VALVES 1/2" - 8" CLASS 300 FULL PORT

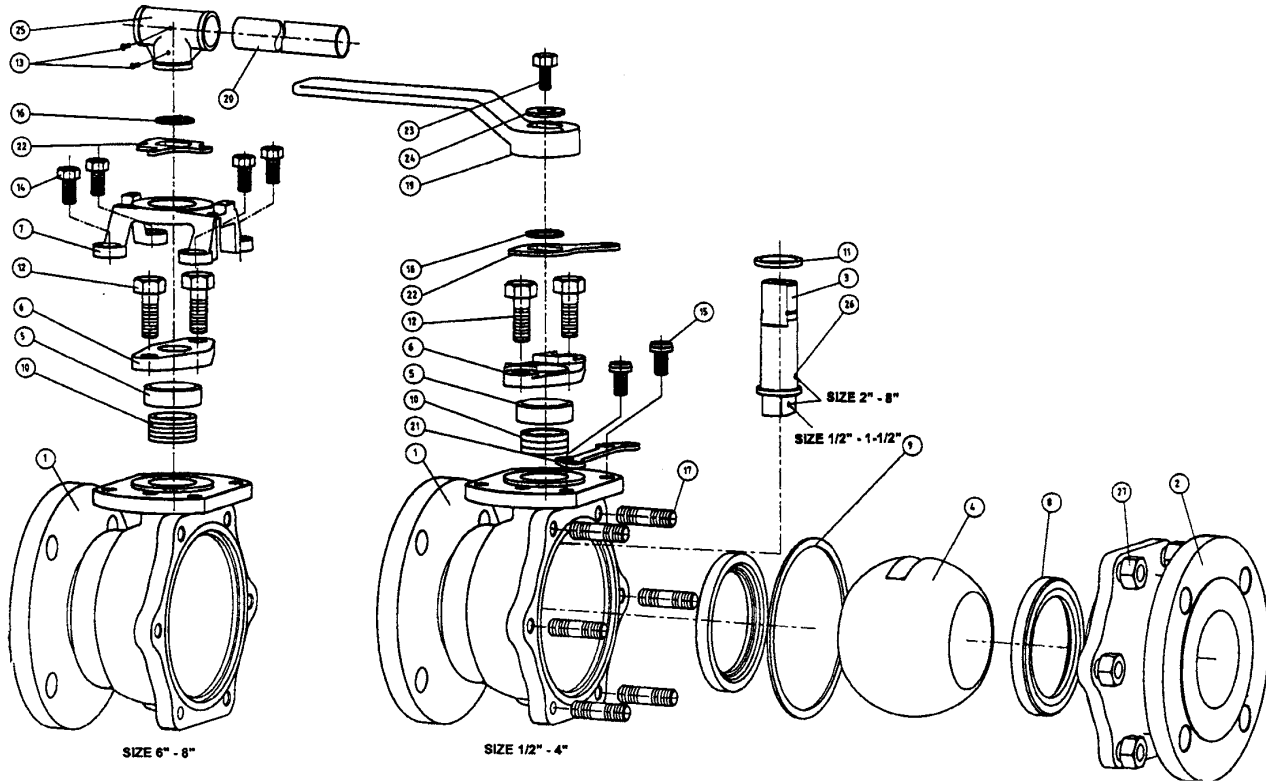

SIZE 6" - 8"

SIZE 1/2" - 4"

DESIGN STANDARDS

Shell Wall Thickness	ANSI B16.34
Pressure Temp Rating	ANSI B16.34
Pressure Test	API 598
Face to Face Dimensions	ANSI B16.10
End Flange Dimensions	ANSI B16.5
Mounting Pad	ISO 5211
Fire Safe	API 607 4th Edition *

*Valve must contain graphite packing and stainless spiral wound graphite gasket to be Fire Safe. Any change in seal components can affect the fire-safe rating of the valve.

No.	Part Name	Figure Number 6306FS Stainless	Figure Number 6305FS Carbon Steel
1.	Body	A351-CF8M	A216-WCB
2.	Cap	A351-CF8M	A216-WCB
3.	Stem	A276-316	A276-316
4.	Ball	A351-CF8M	A351-CF8M
5.	Gland	A276-316	A276-316
6.	Gland Flange	A351-CF8	A351-CF8
7.	Yoke	A351-CF8	A216-WCB
8.	Seat	RTFE 15% Glass	RTFE 15% Glass
9.	Gasket	SPW 316 + Graphite	SPW 316 + Graphite
10.	Gland Packing	Expanded Graphite + Corrosion Inhibitor	
11.	Thrust Washer	RTFE 15% Glass	RTFE 15% Glass
12.	Gland Bolt	A193-B8	A193-B8
13.	Set Screw	A193-B8	A193-B8
14.	Yoke Bolt	A193-B8	A193-B7
15.	Locking Bolt	A193-B8	A193-B8
16.	Snap Ring	A686-W1	A686-W1
17.	Stud Bolt	A193-B8	A193-B7
19.	Vinyl Coated Handle	A108-1020 Sizes 1/2" - 2"	A108-1020 Sizes 1/2" - 2"
19.	Handle	A536 Sizes 2-1/2" - 4"	A536 Sizes 2-1/2" - 4"
20.	Pipe Handle	Carbon Steel Sizes 6" - 8"	Carbon Steel Sizes 6" - 8"
21.	Locking Plate	A167-304	A167-304
22.	Stopper	A167-304	A167-304
23.	Handle Bolt	A193-B8	A193-B8
24.	Washer	A167-304	A167-304
25.	Handle Guide "T"	A216-WCB	A216-WCB
26.	Anti Static Device	SS316	SS316
27.	Stud Bolt Nut	A194-8	A194-2H

Warren® VALVES

STAINLESS STEEL CAST BALL VALVES 1/2" - 8" CLASS 300 FULL PORT

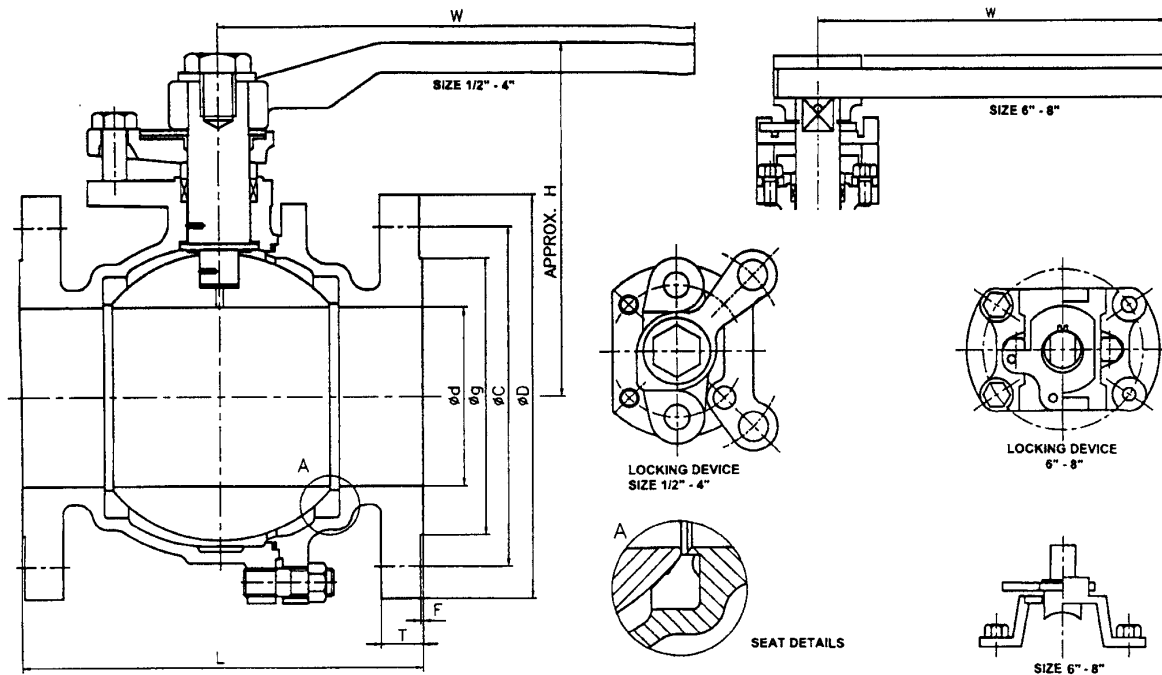

DIMENSIONAL DATA

Size	d	L	H	W	D	C	g	T	F	Cv Value Approx.	Weight (lb.) Approx.
1/2"	0.51	5.50	3.30	5.10	3.50	2.62	1.38	0.56	.0625	26	5.30
3/4"	0.75	6.00	3.46	5.10	4.62	3.25	1.69	0.62	.0625	61	7.95
1"	1.00	6.50	4.01	6.10	4.88	3.50	2.00	0.69	.0625	113	11.25
1-1/2"	1.50	7.50	5.19	9.10	6.12	4.50	2.88	0.81	.0625	270	23.80
2"	2.00	8.50	5.79	9.10	6.50	5.00	3.62	0.88	.0625	500	31.30
2-1/2"	2.50	9.50	5.98	13.80	7.50	5.88	4.12	1.00	.0625	800	46.80
3"	3.00	11.13	6.93	13.80	8.25	6.62	5.00	1.12	.0625	1200	62.80
4"	4.00	12.00	8.27	17.70	10.00	7.88	6.19	1.25	.0625	2200	110.5
6"	6.00	15.86	13.03	23.60	12.50	10.62	8.50	1.44	.0625	5300	220.5
8"	8.00	19.75	15.98	31.50	15.00	13.00	10.62	1.62	.0625	9700	392.0