

DESIGN: API 602/ISO15761, NACE MR 01-75

MATERIALS LIST

NO.	NAME	MATERIAL
1	BODY	ASTM A105N+STL#6
4	DISC	ASTM A182 Gr.F6A+STL#6
5	STEM	ASTM A182 Gr.F6A
9	BONNET	ASTM A105N
11	BODY SEAL	SPW 304+GRAPHITE
14	STEM PACKING	FLEXIBLE GRAPHITE
15	GLAND	ASTM A276 Gr.410
16	GLAND NUT	ASTM A194 Gr.2HM
18	YOKE SLEEVE	ASTM A276 Gr.410
19	HANDWHEEL	ASTM A197
23	HANDLE WASHER	STAINLESS STEEL
24	H.W.NUT	ASTM A194 Gr.2H
25	NAMEPLATE	SS304
35	BODY BOLT	ASTM A193 Gr.B7M
42	GLAND BOLT	ASTM A193 Gr.B8
47	GLAND FLANGE	ASTM A105

DIMENSIONS

SIZE		PORT	L	L2	ØE	H	SW	Wt.
DN8	1/4"	0.24	3.11	0.39	3.94		0.56	
DN10	3/8"	0.24	3.11	0.39	3.94		0.69	
DN15	1/2"	0.39	3.62	0.39	3.94		0.86	
DN20	3/4"	0.51	4.37	0.51	4.72		1.07	
DN25	1"	0.69	4.72	0.51	5.91		1.33	
DN40	1-1/2"	1.13	6.77	0.51	7.09		1.92	
DN50	2"	1.26	7.09	0.63	7.87		2.41	



	APPROVED BY.	CHECK BY.	DRAWN BY.	DRAWINGNO.	MATERIAL	UNIT	DESCRIPTION
SIGN	T.H.KUO	DATE	BLUE	FGB-1500	MATERIALS LIST	inch	FORGED STEEL GLOBE VALVES, SOCKET WELDING END, ANSI CLASS 1500
DATE	11/13/2009	11/13/2009	11/13/2009	REVISION 01	SCALE	FREE	

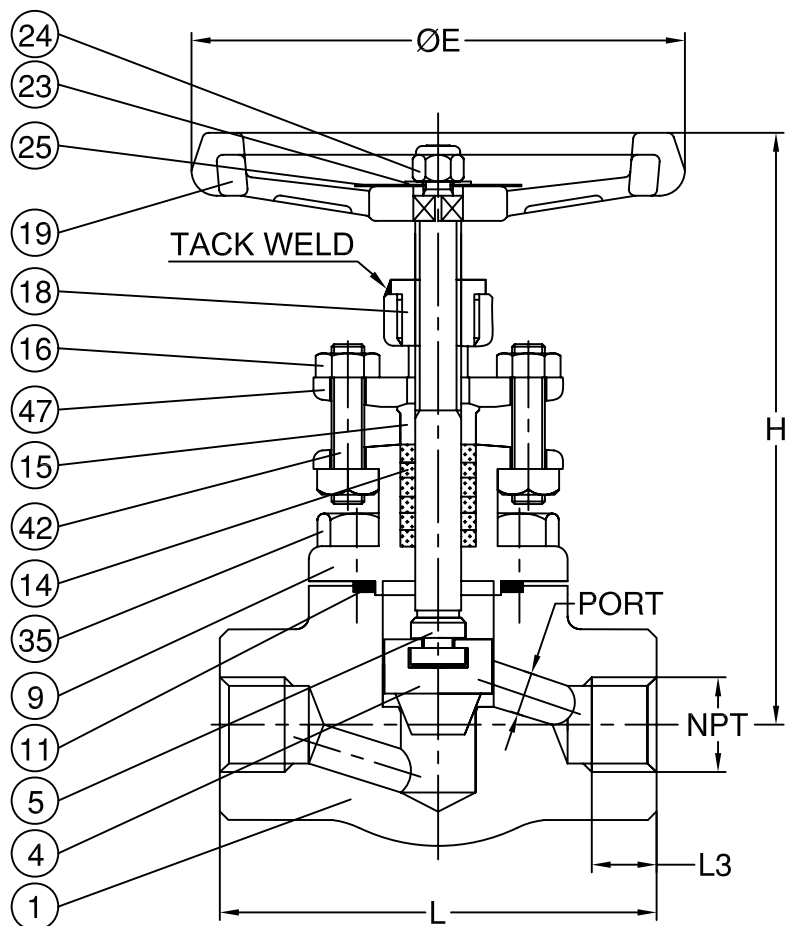

DESIGN: API 602/ISO15761, NACE MR 01-75

MATERIALS LIST

NO.	NAME	MATERIAL
1	BODY	ASTM A105N+STL#6
4	DISC	ASTM A182 Gr.F6A+STL#6
5	STEM	ASTM A182 Gr.F6A
9	BONNET	ASTM A105N
11	BODY SEAL	SPW 304+GRAPHITE
14	STEM PACKING	FLEXIBLE GRAPHITE
15	GLAND	ASTM A276 Gr.410
16	GLAND NUT	ASTM A194 Gr.2HM
18	YOKE SLEEVE	ASTM A276 Gr.410
19	HANDWHEEL	ASTM A197
23	HANDLE WASHER	STAINLESS STEEL
24	H.W.NUT	ASTM A194 Gr.2H
25	NAMEPLATE	SS304
35	BODY BOLT	ASTM A193 Gr.B7M
42	GLAND BOLT	ASTM A193 Gr.B8
47	GLAND FLANGE	ASTM A105

DIMENSIONS

unit:inch

SIZE	PORT	L	L3	ØE	H	NPT	Wt.
DN8	1/4"	0.24	3.11	0.37	3.94	1/4"	
DN10	3/8"	0.24	3.11	0.41	3.94	3/8"	
DN15	1/2"	0.39	3.62	0.54	3.94	1/2"	
DN20	3/4"	0.51	4.37	0.55	4.72	3/4"	
DN25	1"	0.69	4.72	0.69	5.91	1"	
DN40	1-1/2"	1.13	6.77	0.72	7.09	1-1/2"	
DN50	2"	1.26	7.09	0.76	7.87	2"	



	APPROVED BY.	CHECK BY.	DRAWN BY.	DRAWINGNO.	MATERIAL	UNIT	DESCRIPTION
SIGN	T.H.KUO	DATE	BLUE	FGB-1500	MATERIALS LIST	inch	FORGED STEEL GLOBE VALVES, THREADED END, ANSI CLASS 1500
DATE	11/13/2009	11/13/2009	11/13/2009	REVISION 01	SCALE	FREE	

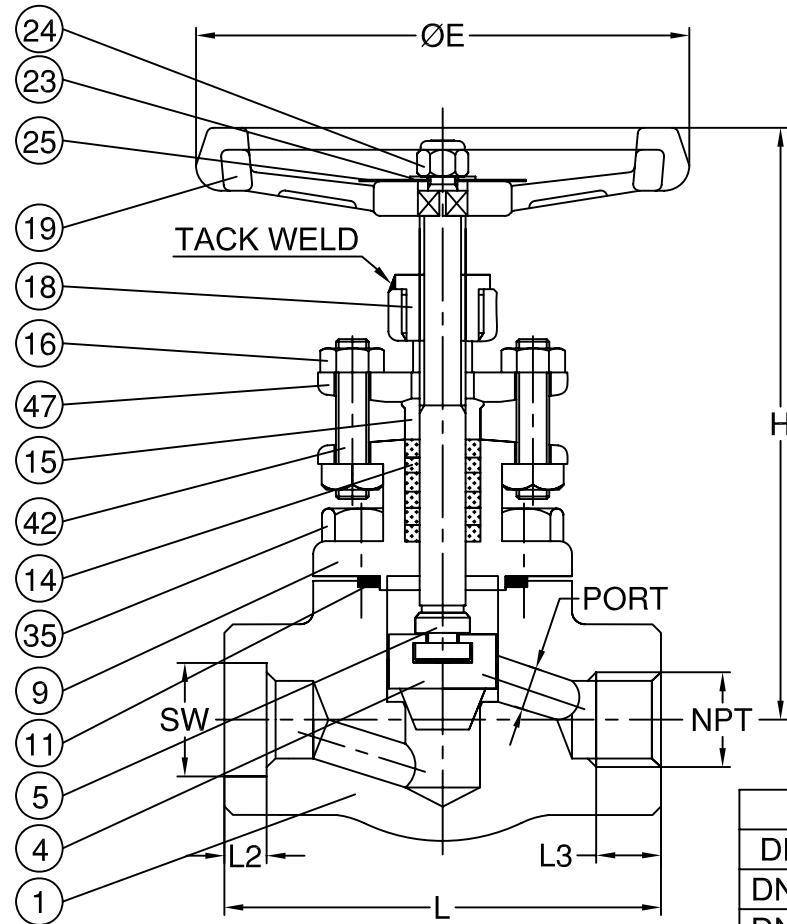

DESIGN: API 602/ISO15761, NACE MR 01-75

MATERIALS LIST

NO.	NAME	MATERIAL
1	BODY	ASTM A105N+STL#6
4	DISC	ASTM A182 Gr.F6A+STL#6
5	STEM	ASTM A182 Gr.F6A
9	BONNET	ASTM A105N
11	BODY SEAL	SPW 304+GRAPHITE
14	STEM PACKING	FLEXIBLE GRAPHITE
15	GLAND	ASTM A276 Gr.410
16	GLAND NUT	ASTM A194 Gr.2HM
18	YOKE SLEEVE	ASTM A276 Gr.410
19	HANDWHEEL	ASTM A197
23	HANDLE WASHER	STAINLESS STEEL
24	H.W.NUT	ASTM A194 Gr.2H
25	NAMEPLATE	SS304
35	BODY BOLT	ASTM A193 Gr.B7M
42	GLAND BOLT	ASTM A193 Gr.B8
47	GLAND FLANGE	ASTM A105

DIMENSIONS

unit:inch

SIZE	PORT	L	L3	ØE	H	NPT	L2	SW	Wt.
DN8	1/4"	0.24	3.11	0.37	3.94	1/4"	0.39	0.56	
DN10	3/8"	0.24	3.11	0.41	3.94	3/8"	0.39	0.69	
DN15	1/2"	0.39	3.62	0.54	3.94	1/2"	0.39	0.86	
DN20	3/4"	0.51	4.37	0.55	4.72	3/4"	0.51	1.07	
DN25	1"	0.69	4.72	0.69	5.91	1"	0.51	1.33	
DN40	1-1/2"	1.13	6.77	0.72	7.09	1-1/2"	0.51	1.92	
DN50	2"	1.26	7.09	0.76	7.87	2"	0.63	2.41	



	APPROVED BY.	CHECK BY.	DRAWN BY.	DRAWINGNO.	MATERIAL	UNIT	DESCRIPTION
SIGN	T.H.KUO	DATE	BLUE	FGB-1500	MATERIALS LIST	inch	FORGED STEEL GLOBE VALVES, THREADED & SOCKET WELDING END, ANSI CLASS 1500
DATE	11/13/2009	11/13/2009	11/13/2009	REVISION 01	SCALE	FREE	