

UNIT	SIZE	L	d	B	C	NPT	H	D	Weight(Kg)
mm	50	170	36.5	63	24	2	100	76	7.5
inch	2	6.69	1.44	2.48	0.94	2	3.94	2.99	7.5
	40	140	28.6	50.5	23.5	1-1/2	80	62	4
	1-1/2	5.51	11.3	1.99	0.93	1-1/2	3.15	2.44	4
	32	140	23	44.1	23.5	1-1/4	80	62	4
	1-1/4	5.51	0.91	1.74	0.93	1-1/4	3.15	2.44	4
	25	102	17.5	35	23	1	64	46	2.5
	1	4.02	0.69	1.38	0.91	1	2.52	1.81	2.5
	20	86	12.7	28	18	3/4	53	37	1.5
	3/4	3.39	0.5	1.10	0.71	3/4	2.09	1.46	1.5
	15	76	9.5	22	17.6	1/2	48	32	1
	1/2	2.99	0.37	0.87	0.69	1/2	1	1.26	1

APPLICABLE STANDARDS & TECHNICAL NOTES:					
Design: ISO 15761			Face to Face Dimension: PER MANUFACTURE		
Inspection & Test: API 598			End Dimension: ASME B1.20.1		
7	Spring	1	ASTM A182-F316		
6	NAME PLATE	1	S.S.304		
5	STUD	4	ASTM A193-B8		
4	GASKET	1	SPW+316 GRAPHITE		
3	DISC	1	ASTM A182-F316		
2	BONNET	1	ASTM A182-F316L		
1	BODY	1	ASTM A182-F316L/STL.6 OVERLAY		
NO.	PART NAME	QTY.	MATERIAL		REMARK
Stan.	ISO 15761	Shell Test	16.6 MPa	Draft	
Class	800LB	Seat Test (Hyd.)	12.2 MPa	Check	
Size	0.5~2	Seat Test (Air)	MPa	Appr.	
Rev.	0	Man.Fig.: P8N V2,S43/12 [-SR,]			
Type	FORGE STEEL PISTON CHECK VALVE				Warren®
UserFig.	MODEL 804				

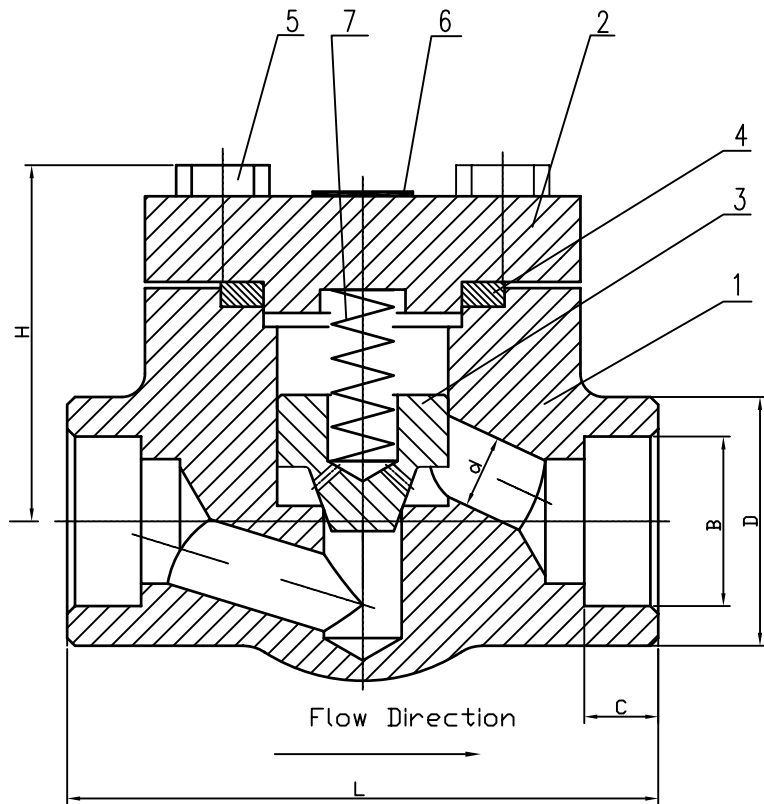

UNIT	SIZE	L	d	B	C	H	D	Weight(Kg)
mm	50	170	36.5	61.2	16	100	76	7.5
inch	2	6.69	1.44	2.41	0.63	3.94	2.99	7.5
	40	140	28.6	48.8	13	80	62	6
	1-1/2	5.51	11.3	1.92	0.51	3.15	2.44	6
	32	140	23	42.7	13	80	62	4.5
	1-1/4	5.51	0.91	1.68	0.51	3.15	2.44	4.5
	25	102	17.5	33.9	13	64	46	2.5
	1	4.02	0.69	1.33	0.51	2.52	1.81	2.5
	20	86	12.7	27.2	13	53	37	1.5
	3/4	3.39	0.5	1.07	0.51	2.09	1.46	1.5
	15	76	9.5	21.8	10	48	32	1
	1/2	2.99	0.37	0.86	0.39	1.89	1.26	1

APPLICABLE STANDARDS & TECHNICAL NOTES:				
Design: ISO 15761			Face to Face Dimension: PER MANUFACTURE	
Inspection & Test: API 598			End Dimension: ASME B16.11	
7	Spring	1	ASTM A182 F316	
6	NAME PLATE	1	S.S.304	
5	STUD	4	ASTM A193-B8	
4	GASKET	1	SPW+316 GRAPHITE	
3	DISC	1	ASTM A182-F316	
2	BONNET	1	ASTM A182-F316L	
1	BODY	1	ASTM A182-F316L/STL.6 OVERLAY	
NO.	PART NAME	QTY.	MATERIAL	REMARK
Stan.	ISO 15761	Shell Test	16.6 MPa	Draft
Class	800LB	Seat Test (Hyd.)	12.2 MPa	Check
Size	0.5~2	Seat Test (Air)	MPa	Appr.
Rev.	0	Man.Fig.: P8S V2,S43/12 [-SR,]		
Type	FORGE STEEL PISTON CHECK VALVE			
UserFig.	MODEL 804			