

NO.	DESCRIPTION	MATERIAL
1	BODY	ASTM A-351 GR CF8M
2	CAP	ASTM A-351 GR CF8M
3	BALL	ASTM A-351 GR CF8M
4	STEM	316 STAINLESS STEEL
5	SEAT	PEEK
6	STEM SEAL	PEEK
7	GASKET	VITON
8	PACKING	GRAPHITE
11	GLAND	316 STAINLESS STEEL
12	NYLOK HANDLE NUT	304 STAINLESS STEEL
13	LOCK HANDLE	304 STAINLESS STEEL

UNLESS OTHERWISE SPECIFIED DIMENSIONS IN MILLIMETERS			
M/C TOLERANCES		CASTING TOLERANCES	
UP TO	100 mm	± 0.25	UP TO 100 mm ± 1.0
OVER	100-250 mm	± 0.40	OVER 200 mm ± 2.0
OVER	250-400 mm	± 0.60	OVER 600 mm ± 2.5
OVER	400-600 mm	± 0.70	ANGLES ± 1.0
OVER	600 mm	± 0.80	

REV. 01	9/24/2002
REV. 02	12/16/2003
APPROVAL	SHEET 1/1
JGN	Sep-02
ISO PATTERN	
F03	1/4" -3/4" CLASS 2500 CAST SEAL-WELDED BALL VALVE ASSEMBLY MODEL NO. W60 ASME B16.34
F03	
F03	
F03	
F03	
F04	DRAWING NUMBER 3160360-SW-1
F04	

SIZE		DIMENSIONS											WT (LBS)
		A	D	H	H1	L	N	N1	R	S	U	øV	
1/4"	INCH	2.65	0.43	2.23	1.53	5.04	0.78	0.35	0.2	0.31	1.42	1.42	1.0
8	MM	67.31	10.92	56.64	38.86	128.01	19.81	8.89	5.08	7.87	36.07	36.07	0.45
3/8"	INCH	2.65	0.43	2.23	1.53	5.04	0.78	0.35	0.2	0.31	1.42	1.42	1.0
10	MM	67.31	10.92	56.64	38.86	128.01	19.81	8.89	5.08	7.87	36.07	36.07	0.45
1/2"	INCH	2.65	0.43	2.23	1.53	5.04	0.78	0.35	0.2	0.31	1.42	1.42	1.0
15	MM	67.31	10.92	56.64	38.86	128.01	19.81	8.89	5.08	7.87	36.07	36.07	0.45
3/4"	INCH	4.25	0.75	2.96	2.21	5.75	1.29	0.35	0.28	0.44	1.65	1.65	1.8
20	MM	158.7	38.1	116.2	98.2	349	63.7	10	10	15.85	70	70	0.8164

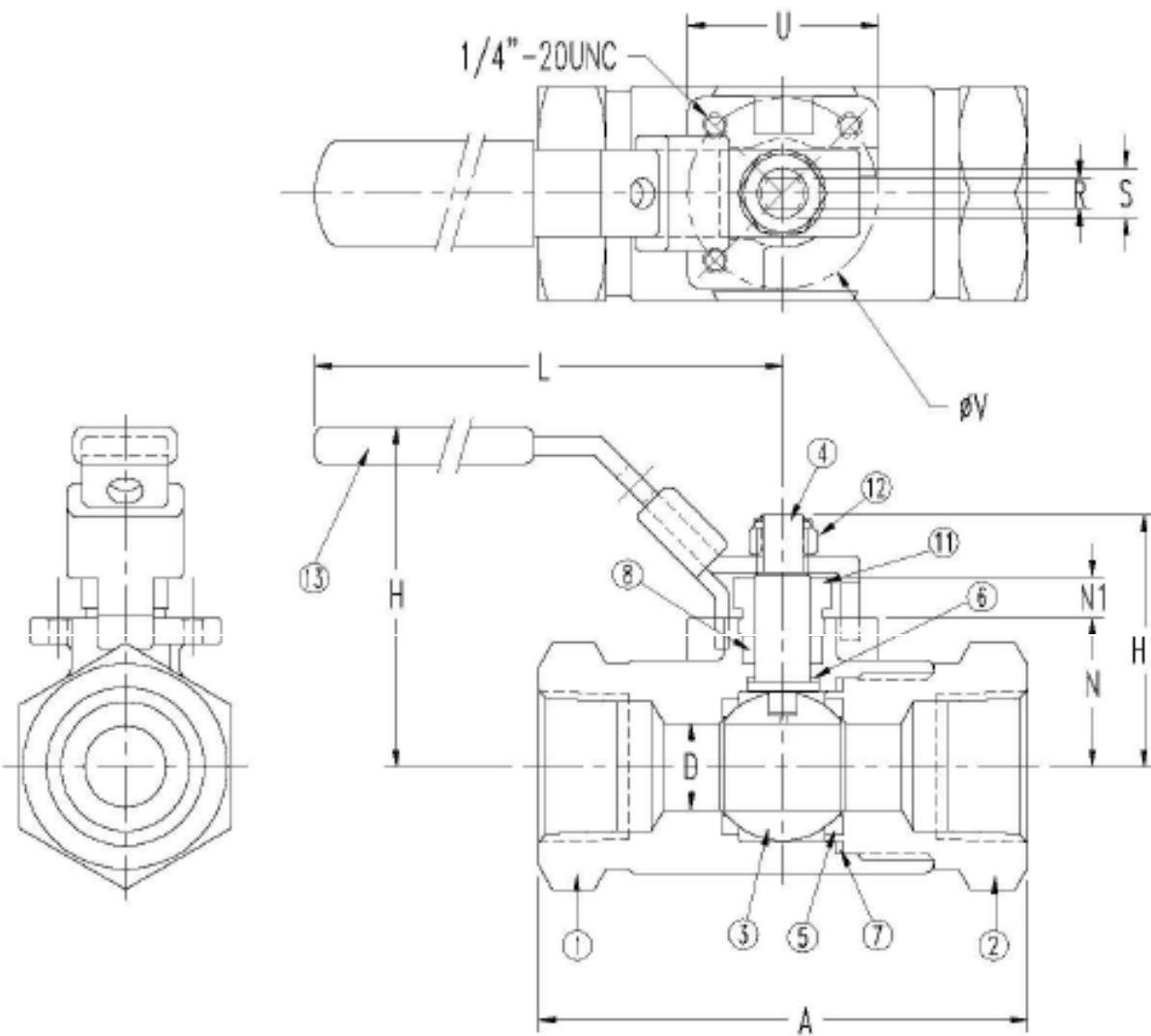

NO.	DESCRIPTION	MATERIAL
1	BODY	ASTM A-351 GR CF8M
2	CAP	ASTM A-351 GR CF8M
3	BALL	ASTM A-351 GR CF8M
4	STEM	316 STAINLESS STEEL
5	SEAT	PEEK
6	STEM SEAL	PEEK
7	GASKET	VITON
8	PACKING	GRAPHITE
11	GLAND	316 STAINLESS STEEL
12	NYLOK HANDLE NUT	304 STAINLESS STEEL
13	LOCK HANDLE	304 STAINLESS STEEL

UNLESS OTHERWISE SPECIFIED DIMENSIONS IN MILLIMETERS			
M/C TOLERANCES		CASTING TOLERANCES	
UP TO	100 mm	± 0.25	UP TO 100 mm ± 1.0
OVER	100-250 mm	± 0.40	OVER 200 mm ± 2.0
OVER	250-400 mm	± 0.60	OVER 600 mm ± 2.5
OVER	400-600 mm	± 0.70	ANGLES ± 1.0
OVER	600 mm	± 0.80	

REV. 01	9/24/2002
REV. 02	12/16/2003
APPROVAL	SHEET 1/1
JGN	Sep-02
ISO PATTERN	
F05	1" -2" CLASS 2500 CAST SEAL-WELDED BALL VALVE ASSEMBLY MODEL NO. W60 ASME B16.34
F05	
F07	
F07	
F07	<b>WARREN</b>
F07	DRAWING NUMBER
F07	3160360-SW-2

SIZE		DIMENSIONS											
		A	D	H	H1	L	N	N1	R	S	U	øV	WT (LBS)
1	INCH	4.25	0.75	2.96	2.21	5.75	1.29	0.35	0.28	0.44	1.65	1.65	2.5
25	MM	108	19.05	75.1	56.1	146	32.7	9	7	11.06	42	42	1.33
1-1/4	INCH												
32	MM												
1-1/2	INCH	5.29	1.5	4.57	3.87	13.74	2.51	0.39	0.39	0.62	2.76	2.76	5.5
40	MM	134.35	38.1	116.2	98.2	349	63.7	10	10	15.85	70	70	2.49
2	INCH	6.25	1.5	4.57	3.87	13.74	2.51	0.39	0.39	0.62	2.76	2.76	8.5
50	MM	158.7	38.1	116.2	98.2	349	63.7	10	10	15.85	70	70	3.85