

NO.	DESCRIPTION	MATERIAL
1	BODY	ASTM A-351 GR CF8M
2	CAP	ASTM A-351 GR CF8M
3	BALL	ASTM A-351 GR CF8M
4	STEM	316 STAINLESS STEEL
5	SEAT	RTFE/TFM/TFE
6	THRUST WASHER	RTFE/TFM/TFE
7	GLAND PACKING	PTFE/GRAPHITE
8	GASKET	GRAPHITE
9	SPRING WASHER	304 STAINLESS STEEL
10	GLAND	316 STAINLESS STEEL
11	LOCK NUT	304 STAINLESS STEEL
12	HANDLE W/VINYL GRIP	304 STAINLESS STEEL

UNLESS OTHERWISE SPECIFIED DIMENSIONS IN MILLIMETERS			
M/C TOLERANCES		CASTING TOLERANCES	
UP TO	100 mm	± 0.25	UP TO 100 mm ± 1.0
OVER	100-250 mm	± 0.40	OVER 200 mm ± 2.0
OVER	250-400 mm	± 0.60	OVER 600 mm ± 2.5
OVER	400-600 mm	± 0.70	ANGLES ± 1.0
OVER	600 mm	± 0.80	

REV. 01	9/24/2002
REV. 02	11/11/2002
APPROVAL	SHEET 1/1
JGN	May-02
ISO PATTERN	
F03	1" - 2" CLASS 900 CAST STEEL 2-PC BALL VALVE ASSEMBLY MODEL NO. W21 ASME B16.34
F03	
F03	
F03	
F03	
F04	<b>WARREN</b> DRAWING NUMBER 3160321-SW-1
F04	

SIZE		DIMENSIONS											WT (LBS)
		A	D	H	H1	L	N	N1	R	S	U	øV	
1/4"	INCH	2.64	0.43	2.23	1.528	5.04	0.783	0.35	0.2	0.31	1.42	1.42	1.0
8	MM	67	11	56.6	38.8	128	19.9	8.9	5	7.94	36	36	
3/8"	INCH	2.64	0.43	2.23	1.528	5.04	0.783	0.35	0.2	0.31	1.42	1.42	1.0
10	MM	67	11	56.6	38.8	128	19.9	8.9	5	7.94	36	36	
1/2"	INCH	2.64	0.43	2.23	1.528	5.04	0.783	0.35	0.02	0.31	1.42	1.42	1.0
15	MM	67	11	56.6	38.8	128	19.9	8.9	5	7.94	36	36	
3/4"	INCH	3.08	0.59	2.72	2.059	5.75	1.031	0.425	0.28	0.44	1.65	1.65	1.8
20	MM	78.3	15	69	52.3	146	26.2	10.8	7	11.06	42	42	

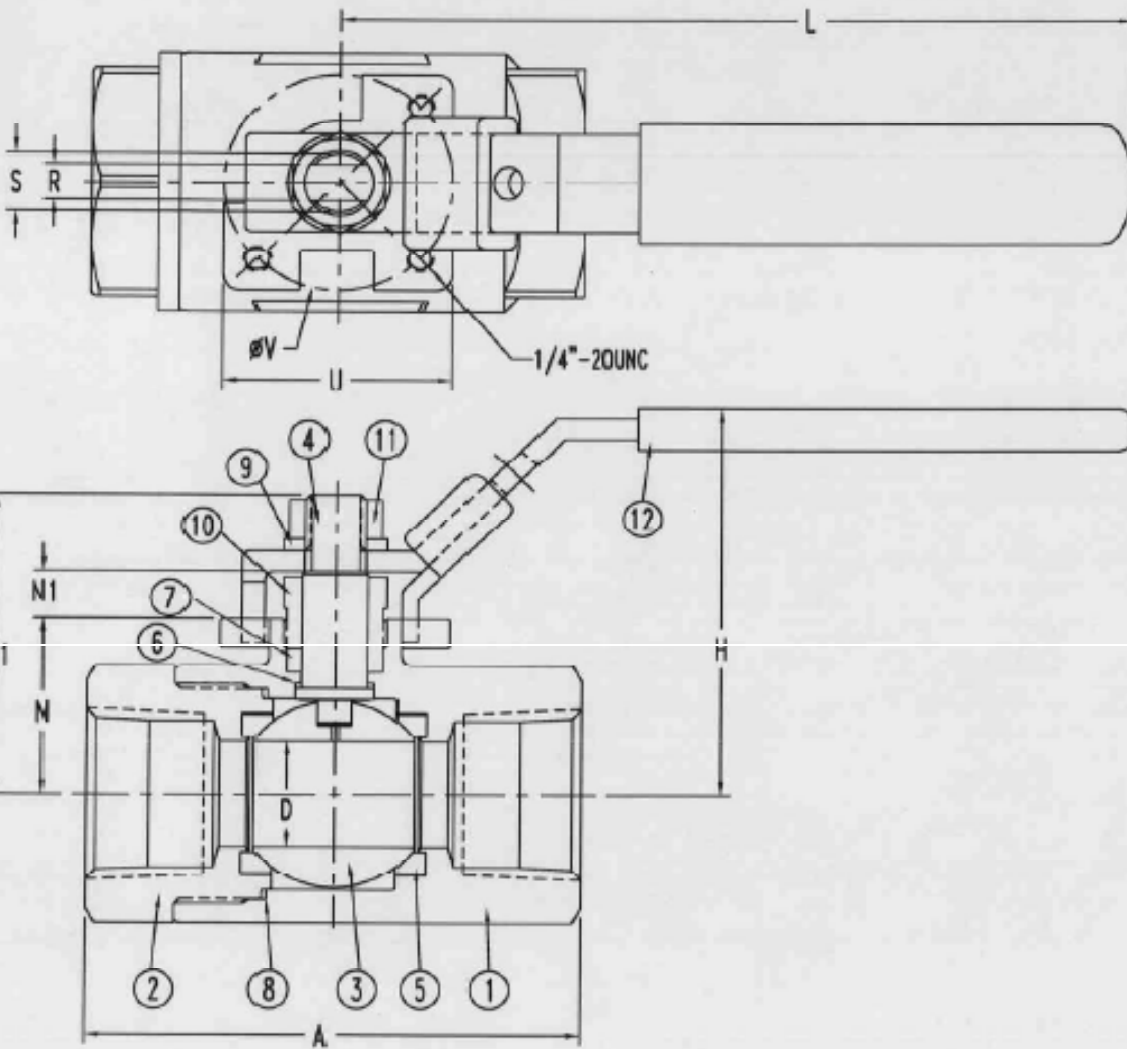

NO.	DESCRIPTION	MATERIAL
1	BODY	ASTM A-351 GR CF8M
2	CAP	ASTM A-351 GR CF8M
3	BALL	ASTM A-351 GR CF8M
4	STEM	316 STAINLESS STEEL
5	SEAT	RTFE/TFM/TFE
6	THRUST WASHER	RTFE/TFM/TFE
7	GLAND PACKING	PTFE/GRAPHITE
8	GASKET	GRAPHITE
9	SPRING WASHER	304 STAINLESS STEEL
10	GLAND	316 STAINLESS STEEL
11	LOCK NUT	304 STAINLESS STEEL
12	HANDLE W/VINYL GR	304 STAINLESS STEEL

UNLESS OTHERWISE SPECIFIED  
DIMENSIONS IN MILLIMETERS

M/C TOLERANCES			CASTING TOLERANCES		
UP TO	100 mm	± 0.25	UP TO	100 mm	± 1.0
OVER	100-250 mm	± 0.40	OVER	200 mm	± 2.0
OVER	250-400 mm	± 0.60	OVER	600 mm	± 2.5
OVER	400-600 mm	± 0.70	ANGLES		± 1.0
OVER	600 mm	± 0.80			

REV. 01	9/24/2002
REV. 02	11/11/2002
APPROVAL	SHEET 1/1
JGN	May-02

SIZE		DIMENSIONS											WT (LBS)
		A	D	H	H1	L	N	N1	R	S	U	øV	
1	INCH	3.54	0.81	2.87	2.327	5.75	1.33	0.402	0.28	0.44	1.65	1.65	2.5
25	MM	90	20.6	72.8	59.1	146	33.9	10.2	7	11.06	42	42	
1-1/4	INCH	4	0.98	3.47	2.764	7.2	1.61	0.445	0.35	0.56	1.97	1.97	3.9
32	MM	101.6	25	88.2	70.2	183	40.9	11.3	9	14.22	50	50	
1-1/2	INCH	4.25	1.25	3.69	2.98	7.76	1.83	0.445	0.35	0.56	1.97	1.97	5.5
40	MM	108	31.75	93.7	75.7	197	46.4	11.3	9	14.22	50	50	
2	INCH	4.94	1.5	3.93	3.177	7.76	2	0.472	0.35	0.56	1.97	1.97	8.5
50	MM	125.6	38.1	99.7	80.7	197	50.7	12	9	14.22	50	50	

ISO PATTERN	1" - 2" CLASS 900 CAST STEEL 2-PC BALL VALVE ASSEMBLY MODEL NO. W21 ASME B16.34
F04	
F04	
F05	
F05	
F05	<b>WARREN</b> DRAWING NUMBER 3160321-SW-2
F05	
F05	