

# Fig No: WARREN-7156

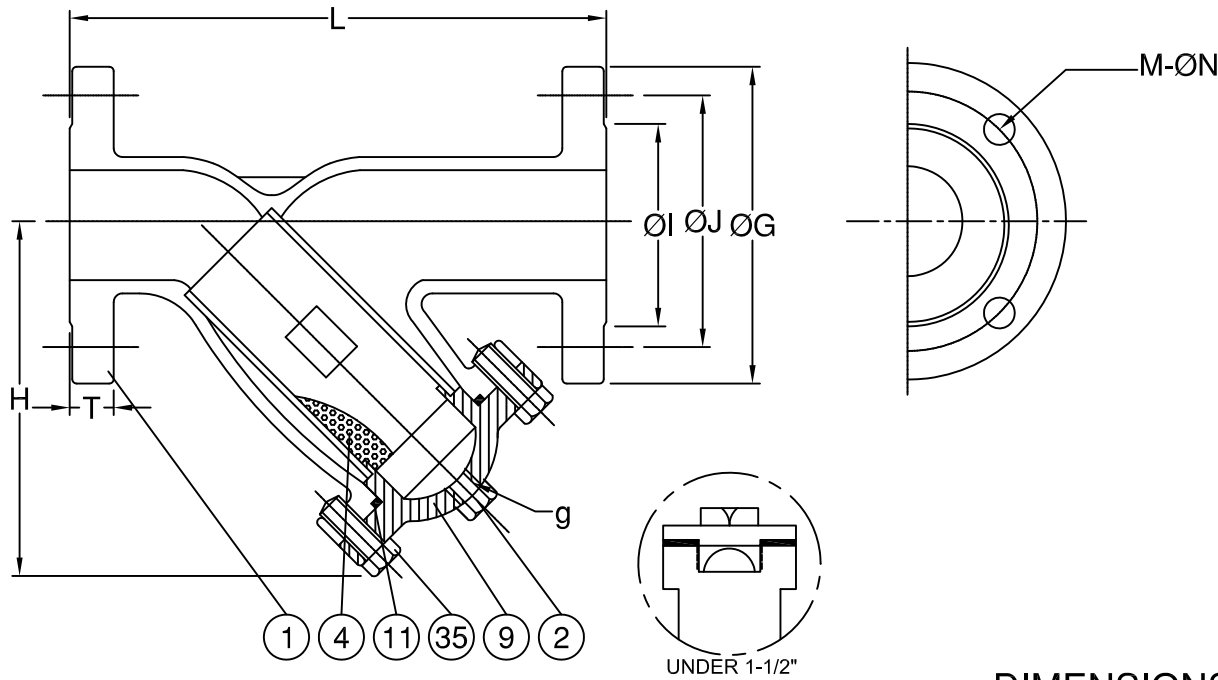

## MATERIALS LIST

NO.	PART NAME	MATERIAL
1	BODY	ASTM A351 Gr.CF8M
2	BELOW OFF PLUG	ASTM A351 Gr.CF8
4	SCREEN	SS304
9	BONNET	ASTM A351 Gr.CF8M
11	GASKET	PTFE.
35	BODY BOLT	ASTM A193 Gr.B8

("H" SIZE REFERENCE USE) ± 2.5 mm  
FOR REFERENCE ONLY

## DIMENSIONS

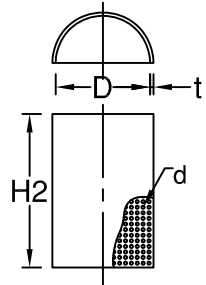

SIZE	L	H	ØG	ØJ	ØI	T	g	M	ØN	unit:inch					
										Weight(lbs)	H2	D	d	t	
DN15	1/2"	5.98	2.76	3.50	2.38	1.37	0.44	--	4	0.59	6.61	1.87	0.73	0.04	0.02
DN20	3/4"	7.44	3.07	3.85	2.76	1.69	0.44	--	4	0.59	6.61	2.17	0.94	0.04	0.02
DN25	1"	7.44	3.62	4.25	3.13	2.00	0.44	--	4	0.59	8.82	2.8	1.16	0.04	0.02
DN40	1-1/2"	7.08	4.29	5.00	3.88	2.87	0.56	--	4	0.59	14.33	3.15	1.65	0.04	0.02
DN50	2"	8.58	5.74	5.98	4.74	3.62	0.62	1/2	4	0.75	26.46	4.25	1.89	0.04	0.02
DN65	2-1/2"	10.28	7.09	7.01	5.47	4.13	0.69	3/4	4	0.75	37.48	5.87	2.48	0.04	0.02
DN80	3"	11.61	7.87	7.48	6.00	5.00	0.75	1	8	0.75	44.09	7.05	3.19	0.04	0.02
DN100	4"	14.21	9.45	9.02	7.50	6.18	0.94	1-1/2	8	0.75	74.96	7.64	3.62	0.12	0.03
DN125	5"	18.5	1.18	10.00	8.50	7.32	0.94	2	8	0.87	116.84	9.69	5.12	0.12	0.04
DN150	6"	18.46	13.39	10.980	9.51	8.50	1.00	2	8	0.87	143.30	10.75	5.91	0.12	0.04
DN200	8"	24.80	18.11	13.5	11.75	10.63	1.13	2	12	0.87	235.89	12.68	8.03	0.12	0.04
DN250	10"	26.10	19.49	15.98	14.25	12.76	1.19	2	12	0.98	388.01	14.96	10.00	0.12	0.04
DN300	12"	30.39	22.64	19.02	17.01	15.00	1.22	2	16	0.98	540.13	17.91	11.81	0.12	0.04

**warren alloy**

	APPROVED BY.	CHECK BY.	DRAWN BY.	DRAWING NO.		MATERIAL	UNIT	DESCRIPTION	
SIGN	MIKE	ENZO	VIC	WARREN-7156		MATERIALS LIST	inch	Y-STRAINERS, FLANGED END, ANSI CLASS 150	
DATE	06/30/2010	06/30/2010	06/30/2010	REVISION	02	SCALE	FREE		